

SUPPLEMENTAL AIRPLANE MAINTENANCE MANUAL

DA 42 NG

RETROFIT INSTALLATION OF

AUSTRO ENGINE E4-B

This supplemental AMM is approved in conjunction with the Optional Design Change Advisory OÄM 42-171 and OÄM 42-176 and is valid in conjunction with the basic DA 42 NG Airplane Maintenance Manual (AMM), Doc. No. 7.02.15.

The limitations and information contained herein either supplement or, in the case of conflict, override those in the AMM.

Doc. No. : **7.02.15-003**

Date of Issue : **01-Jun-2009**

Design Change Advisory : **OÄM 42-171 and**
OÄM 42-176

The technical information contained in this document has been approved under the authority of DOA No. EASA.21J.052.

Intentionally left blank.

TABLE OF CONTENTS

CHAPTER 01 – INTRODUCTION 1

 1. General..... 1

CHAPTER 03 – GENERAL DESCRIPTION OF THE AIRPLANE 1

 3. Equipment Data 1

CHAPTER 05 – TIME LIMITS AND MAINTENANCE CHECKS 1

Section 05-20 – Scheduled Maintenance Checks..... 1

Maintenance Practices – Maintenance Checklist DA 42 NG..... 1

 4. Maintenance Checklist Zones..... 1

 7. Maintenance Check Flight Report..... 2

CHAPTER 11 – PLACARDS AND MARKINGS..... 1

Section 11-20 – Exterior Placards and Markings..... 1

 1. General..... 1

Section 11-30 – Interior Placards and Markings..... 1

 2. Description 1

CHAPTER 22 – AUTO FLIGHT..... 1

Section 22-11 – KAP 140 Autopilot 1

 1. General..... 1

 2. Description 1

Maintenance Practices 201

 1. General..... 201

 2. Remove/Install the Flight Control Computer 201

 3. Remove/Install the KCM 100 Configuration Module..... 203

 5. Remove/Install the Roll Servo..... 205

 6. Remove/Install the Roll Servo Clutch 206

 7. Remove/Install the Pitch Servo..... 208

 8. Remove/Install the Pitch Servo Clutch..... 209

 9. Remove/Install the Pitch Trim Servo..... 211

 10. Remove/Install the Pitch Trim Servo Clutch 212

 11. Adjust the Bridle Cable Tension..... 213

12.	Adjust the Servo Clutch Torques	214
13.	Mechanical Test of the Autopilot System.....	215
CHAPTER 31 – INDICATING SYSTEMS		1
Section 31-10 – Instrument and Control Panels		1
2.	Instrument Panel Description	1
CHAPTER 52 – DOORS.....		1
Section 52-10 – Canopy and Passenger Door		1
2.	Canopy Description and Operation	1
3.	Passenger Door Description and Operation	3
CHAPTER 92 – WIRING DIAGRAMS		1
1.	General.....	1

CHAPTER 01 – INTRODUCTION

1. General

This Supplemental AMM supplies the information necessary to do the maintenance of a DA 42 NG previously manufactured as a DA 42 with subsequent installation of Austro Engine E4-B engines.

The information contained in this Supplemental AMM is to be used in conjunction with the complete DA 42 NG AMM, Doc. No. 7.02.15.

Further, use the following manuals in conjunction with the Airplane Maintenance Manual, and the related Service Bulletins (if the KAP 140 A/P is installed):

- The Honeywell Flightline Maintenance Manual Bendix/King KAP 140 Flight Control System, Manual Number 006-15574-0002.
- The Honeywell Installation Manual Bendix/King KAP 140 Flight Control System, Manual Number 006-00991-0006.

Intentionally left blank.

CHAPTER 03 – GENERAL DESCRIPTION OF THE AIRPLANE

3. Equipment Data

In any case, the parts must have exactly those part numbers shown in the Equipment List in Chapter 6 of the

- Airplane Flight Manual, Doc. No. 7.01.15-E, latest revision, or
- Airplane Flight Manual Supplement O03, Doc. No. 7.01.15-E-O03, latest revision, or
- Airplane Flight Manual Supplement A13, Doc. No. 7.01.15-E-A13, latest revision (if the KAP 140 A/P is installed).

ATA Chapter	Equipment/System	Manufacturer/Address	Direct Shipping Approved
22	Autopilot System (if KAP 140 A/P is installed):	Honeywell International Inc. One Technology Center 23500 West 105 th Street Olathe, Kansas 66061 USA Tel: (913) 712-0400 Fax: (913) 791-1302	yes

Intentionally left blank.

CHAPTER 05 – TIME LIMITS AND MAINTENANCE CHECKS

Section 05-20 – Scheduled Maintenance Checks

Maintenance Practices – Maintenance Checklist DA 42 NG

4. Maintenance Checklist Zones

C. Cabin

(3) Flight Control System in Cabin

		Interval					
	Inspection Items, Flight Control System in Cabin	100	200	1000	2000	Time	Initials
<p>Note: The mechanical check of the KAP 140 autopilot system (if installed) is not mandatory. It is however recommended to do this check at the times shown below.</p>							
14.	<p>Do a mechanical check of the KAP 140 autopilot system (if installed).</p> <p>Refer to Section 22-11 of this Supplemental AMM.</p>			X	X	1yr.	

(5) Miscellaneous Items in Cabin

		Interval					
	Inspection Items, Cabin, Miscellaneous	100	200	1000	2000	Time	Initials
4.	<p>If the sun visors (OÄM 42-101 or OÄM 42-142) are installed:</p> <ul style="list-style-type: none"> – Check for obvious damage. – Check press-studs for lack of retention force. 		X	X	X		

7. Maintenance Check Flight Report

	MAINTENANCE CHECK FLIGHT (See Maintenance Checklist for Applicability)	DA 42 NG		
		Supplemental O03 Page		
Registration:	Pilot:	Airdrome:		
Date:	Take-Off:	Landing:		
Functional Check, Flight Behavior		Findings		
		N/A	NO	YES
ON GROUND, ENGINES ON				
If KAP 140 A/P is installed: Altimeters (G1000 and backup), autopilot: QNH adjustment.				
CRUISE (in accordance with AFM)				
Autopilot (if KAP 140 A/P is installed): –Wings level mode. –HDG mode. –NAV mode (if required). –ALT / VS preselect and hold. –CWS (control wheel steering) button. –Disconnect (red button).				

CHAPTER 11 – PLACARDS AND MARKINGS
Section 11-20 – Exterior Placards and Markings

1. General

Canopy/Door Operation Placards if MÄM 42-097 Is Not Carried Out:

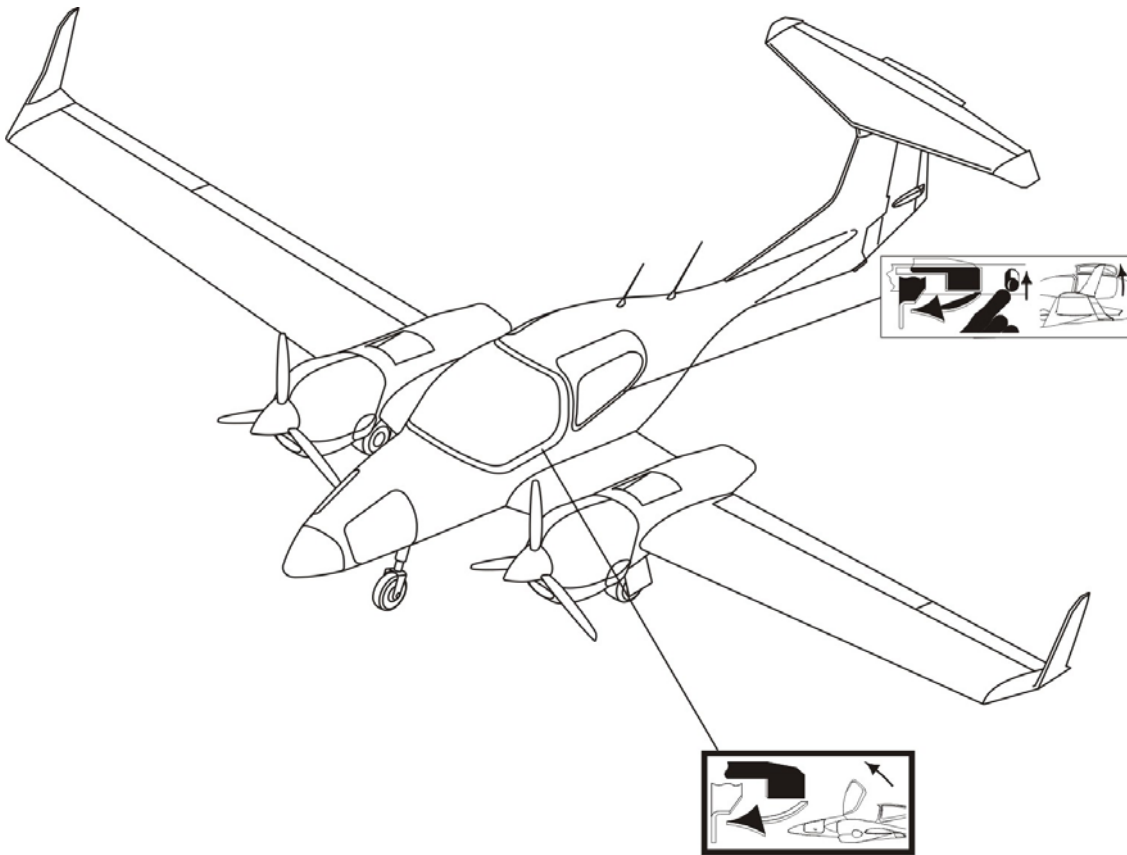

Figure 1: Exterior Placards and Markings - MÄM 42-097 Not Carried Out

Intentionally left blank.

Section 11-30 – Interior Placards and Markings

2. Description

On LH canopy Frame if the KAP 140 A/P Is Installed:

Limitations for KAP 140 Autopilot System:	
Engine Power (LH & RH) is limited to max. 80% Load Indication during Autopilot Operation.	
Do not use AP during single engine operation.	
Autopilot DISC during take-off and landing.	
Maximum speed for autopilot operation is 180 KIAS.	
Minimum speed for autopilot operation is 90 KIAS.	
<u>Minimum Altitude for Autopilot Operation:</u>	
Cruise, Climb, Descent and Maneuvering	: 800 feet AGL
Approach (130 KIAS or less)	: 200 feet AGL
Approach (above 130 KIAS)	: 250 feet AGL
Departure	: 200 feet AGL

Figure 1: Interior Placards and Markings – KAP 140 A/P Installed

Canopy/Door Operation Placards if MÄM 42-097 Is Not Carried Out:

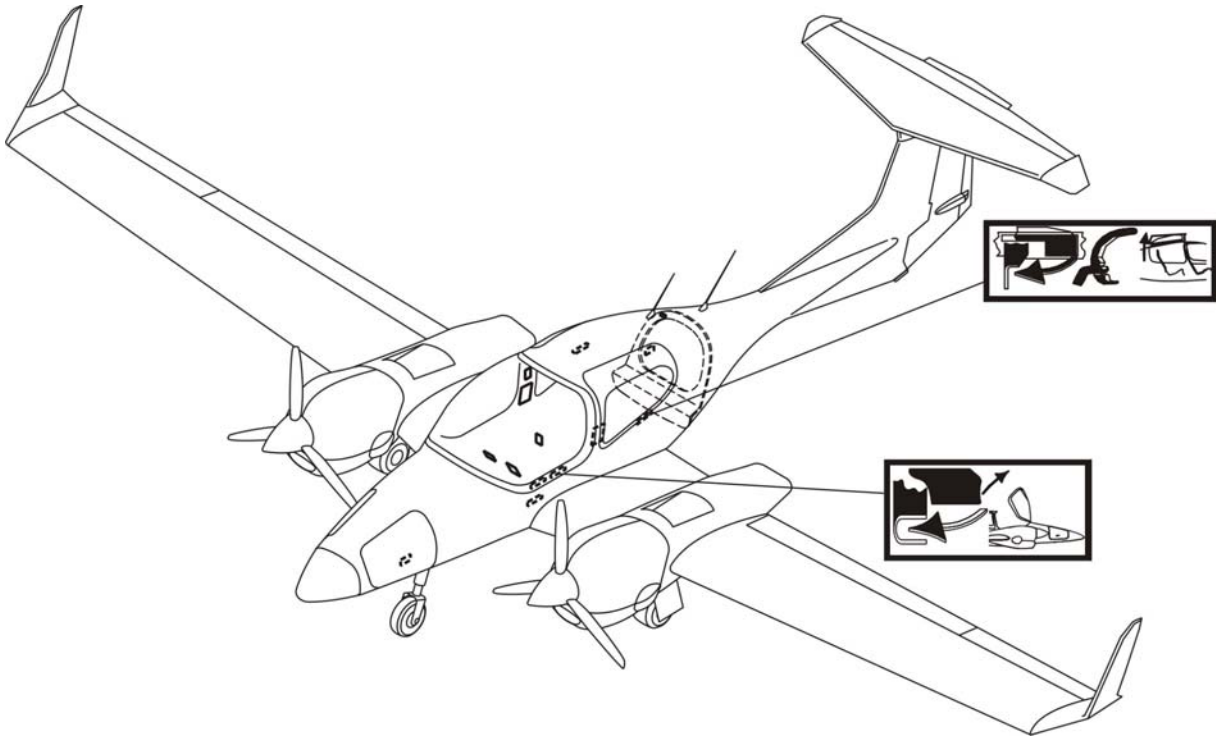

Figure 2: Exterior Placards and Markings - MÄM 42-097 Not Carried Out

CHAPTER 22 – AUTO FLIGHT

Section 22-11 – KAP 140 Autopilot

1. General

This Section tells you about the KAP 140 autopilot system that is installed in the DA 42 NG. Refer to Section 22-10 in the AMM, Doc. No. 7.02.15, latest revision if the GFC 700 autopilot system is installed.

2. Description

The KAP 140 autopilot system is a digital flight control system that provides roll, pitch, and pitch trim steering with altitude preselect.

The system has the following components (refer to Figure 1):

- KC 140 flight control computer (FCC).
- KCM 100 configuration module.
- Turn coordinator with autopilot pick-off.
- KS 271C roll servo.
- KS 270C pitch servo.
- KS 272C pitch trim servo.
- KM 275 and KM 277 servo mounts.
- Coupling to the Garmin G1000 integrated cockpit system (ICS).

Heading input is supplied for the KAP 140 autopilot by the Garmin G1000 integrated cockpit system (ICS). Refer to Section 31-40 in the AMM for more data about the ICS.

The KAP 140 roll axis features include wing leveler, heading select, and VOR/LOC intercept and tracking. The KAP 140 is also coupled to the ICS for navigation information. Roll rate information is derived from the turn coordinator.

Pitch axis features include vertical speed, glideslope and altitude hold along with the optional altitude preselect. Pitch information is derived from a pressure sensor and accelerometer. Internal monitors keep constant track of the KAP 140's status and provide for automatic shutdown of the autopilot or trim system in the event of a malfunction.

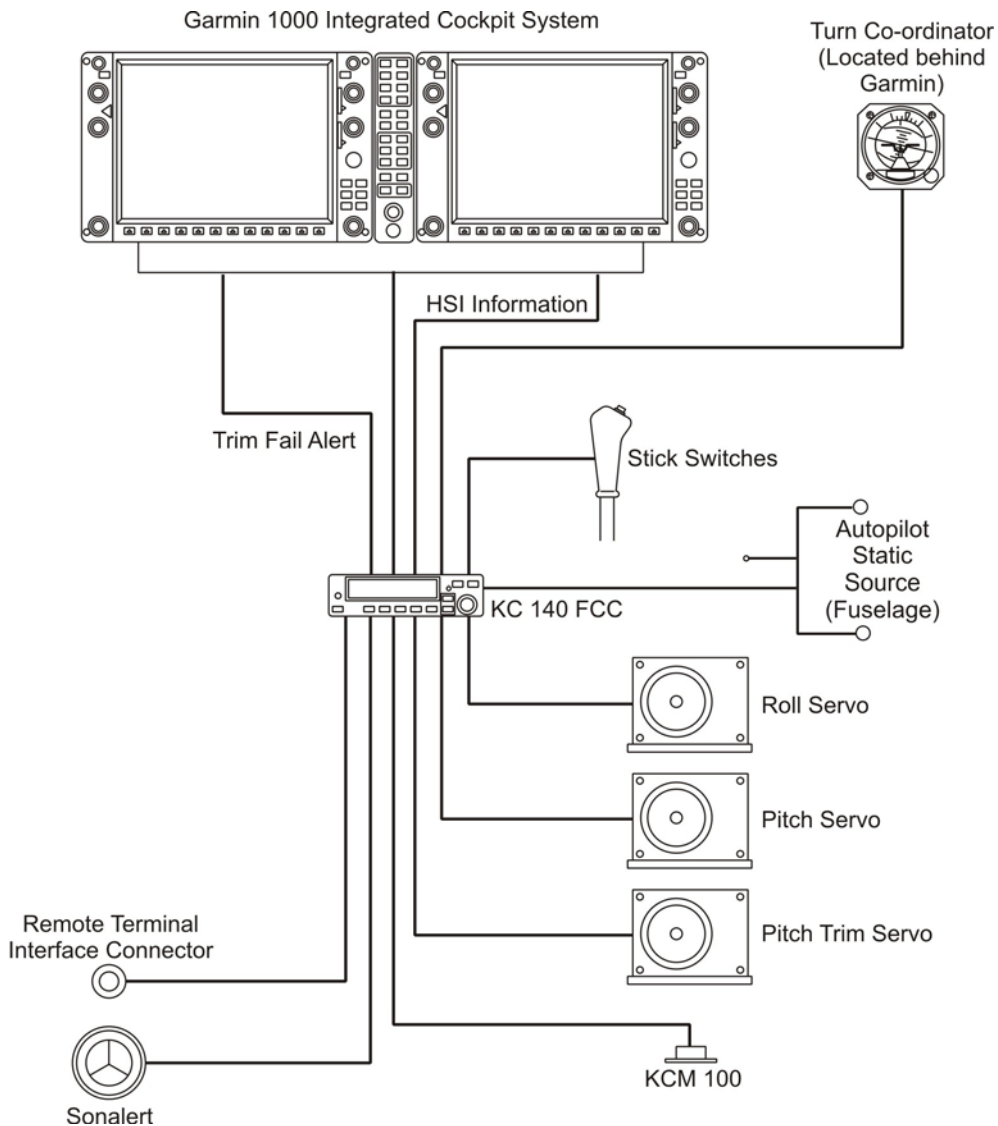

Figure 1: KAP 140 Autopilot System Schematic Diagram

A. Bendix/King KAP 140 Flight Control Computer

Figure 2 shows the Bendix/King KAP 140 flight control computer. It is located in the instrument panel, at the bottom.

The Bendix/King KAP 140 has the following annunciators on the front panel, above the AP button:

- 'P' (pitch axis) annunciator. It indicates failure of the pitch axis and will either disengage the autopilot or does not allow engagement of the pitch axis. The 'P' annunciator may illuminate with the autopilot disengaged. This condition can occur during maneuvering flight when g thresholds are exceeded. The autopilot monitor will not allow engagement during illumination.
- 'R' (roll axis) annunciator. It indicates failure of the roll axis and will disengage the autopilot or does not allow engagement.

The Bendix/King KAP 140 controls the following annunciator on the ICS alerts panel (also see Section 31-40 in the AMM):

- TRIM FAIL annunciator. It illuminates whenever the automated pre-flight self test detects a pitch trim fault or a continuous monitoring system detects a pitch trim fault in flight. Refer to the EMERGENCY PROCEDURES for proper response to a pitch trim fault.

The Bendix/King KAP 140 has a display which shows the following:

- Pitch and roll mode displays. Displays the active pitch modes (VS, ALT, ARM, ALT, GS ARM, GS) and roll modes (ROL, HDG, NAV ARM, NAV, APR ARM, APR, REV ARM, REV). Also displayed will be a flashing AP annunciation (5 seconds) at each autopilot disconnect, accompanied by an aural alert (for 2 seconds).
- PT (pitch trim) annunciation. It indicates the direction of required pitch trim. With electric trim installed, the annunciation simply provides status to the autopilot request for auto trim. A solid indication represents the lowest demand level for trim, whereas a flashing annunciation implies a greater demand. A solid PT annunciation without an arrow head is an indication of a pitch trim fault. During MET operation, this annunciation can be caused by a stuck MET switch. If the stuck switch fault clears, trim operation will resume.

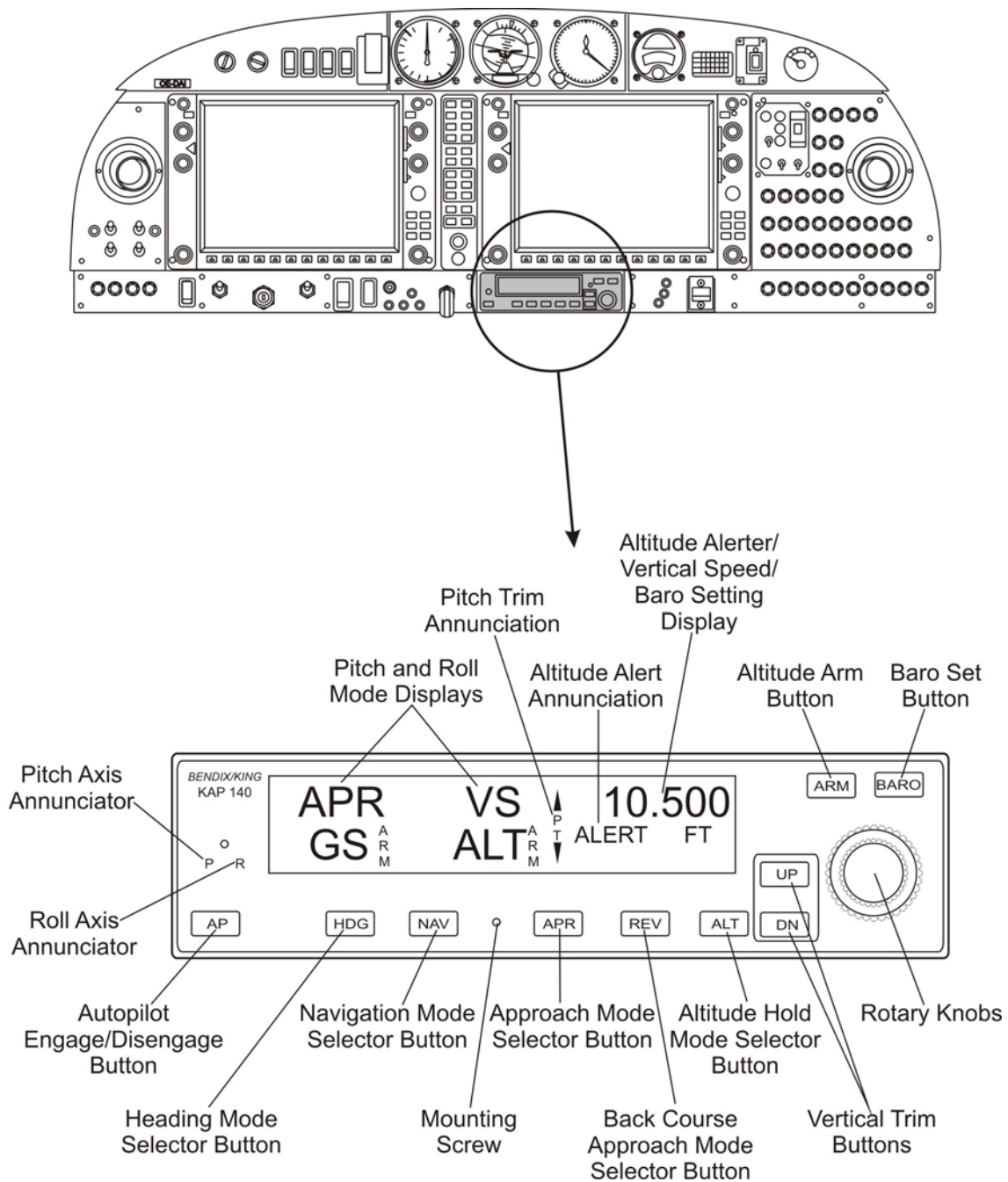

Figure 2: Bendix/King KAP 140 Flight Control Computer

ALERT (altitude alert) annunciation.

- It illuminates continuously in the region of from 200 to 1000 feet from the selected altitude if the airplane was previously outside of this region.
- It flashes for two seconds the first time the airplane crossed the selected altitude.
- It flashes continuously in the 200 to 1000 feet region if the airplane was previously inside of this region (i.e., at the selected altitude). Associated with the visual alerting is an aural alert (5 short tones) which occurs 1000 feet from the selected altitude upon approaching the altitude and 200 feet from the selected altitude on leaving the altitude.
- Altitude alert/vertical speed/baro setting display. Normally the altitude alerter selected altitude is displayed. If the UP or DN button is pushed while in VS hold, the display changes to the command reference for the VS mode in FPM for 3 seconds. If the BARO button is pushed, the display changes to the autopilot baro setting in either IN HG or HPA for 3 seconds.

The flight control computer has these controls on the front panel:

- Rotary knobs. These are used to set the altitude alert reference altitude; or may be used immediately after pressing the BARO button, to adjust the autopilot baro setting to match that of the airplane's altimeter when manual adjustment is required.
- AP (autopilot engage/disengage) button. When pushed, it engages the autopilot if all logic conditions are met. The autopilot will engage in the basic roll (ROL) mode which functions as a wing leveler and in the vertical speed (VS) hold mode. The commanded vertical speed may be displayed manually in the upper right corner of autopilot display area if either UP or DN button is pressed. The captured VS will be the vertical speed present at the moment of AP button press. When pressed again, it will disengage the autopilot.
- HDG (heading) mode selector button. When pushed, it will select the 'heading' mode, which commands the airplane to turn to and maintain the heading selected by the heading bug on the HSI. A new heading may be selected at any time and will result in the airplane turning to the new heading. The button can also be used to toggle between HDG and ROL modes. This button may be used to engage the autopilot.
- NAV (navigation) mode selector button. When pushed, will select the navigation mode. The mode provides automatic beam capture and tracking of VOR, LOC or GPS as selected for presentation on the HSI. NAV mode is recommended for enroute navigation tracking.

- APR (approach) mode selector button. When pushed, it will select the navigation mode. The mode provides automatic beam capture and tracking of VOR, GPS, LOC, and glideslope (GS) on an ILS, as selected for presentation on the ICS. APR mode tracking sensitivity is recommended for instrument approaches.
- REV (back course approach) mode selector button. When pushed, it will select the back course approach mode. This mode functions identically to the approach mode except that the autopilot response to LOC signals is reversed.
- ALT (altitude hold) mode select button. When pushed, it will select the altitude hold mode. This mode provides capture and tracking of the selected altitude. The selected altitude is the altitude at the moment the ALT button is pressed. If the ALT button is pressed with an established VS rate present, there will be approximately a 10 % (of VS rate) overshoot, with the airplane returned positively to the selected altitude.
- UP/DN (vertical trim) buttons. The action of these buttons is dependent upon the vertical mode present when pressed. If VS mode is active, the initial button stroke will bring up the commanded vertical speed in the display. Subsequent immediate button strokes will increment the vertical commanded either up or down at the rate of 100 ft/min per button press, or at the rate of approximately 300 ft/min per second if pressed continuously. If the ALT mode is active, incremental button strokes will move the altitude hold reference altitude either up or down by 20 feet per press, or if held continuously will command the airplane up or down at the rate of 500 ft/min, synchronizing the altitude hold reference to the actual airplane altitude upon button release. (Note that the altitude hold reference is not displayed. The display will continue to show the altitude alert reference.)
- ARM (altitude arm) button. It toggles altitude arming on or off. When ALT ARM is annunciated, the autopilot will capture the altitude alert displayed altitude (provided the airplane is climbing or descending in VS to the displayed altitude). ALT hold arming when the autopilot is engaged is automatic upon altitude alert altitude selection via the rotary knobs. Note that the alert functions are independent of the arming process, thus providing full time alerting, even when the autopilot is disengaged.
- BARO (baro set) button. When pushed and released, it will change the display from the altitude alert selected altitude to the baro setting display (either IN HG or HPA) for 3 seconds. If pushed and held for 2 seconds, it will change the baro setting display from IN HG to HPA or vice versa. Once the baro setting display is visible, the rotary knobs may be used to manually adjust the baro setting if the system configuration does not employ automatic correction.

The flight control computer is connected to these controls on the control sticks:

- AP DISC (autopilot disconnect) switch on pilot's and co-pilot's stick. When pressed, it will disengage the autopilot, and interrupt electric trim power.
- Manual electric trim switches on the pilot's stick. When both switches are pressed in the same direction, they will activate pitch trim in the selected direction. If only one switch is moved, the trim system will not operate. If one switch fails or is moved and held for 3 seconds, the trim monitoring system will detect a switch failure resulting in a PT annunciation on the autopilot display and the disabling of the electric trim system. Autopilot power will have to be cycled to clear the fault. Use of manual electric trim during autopilot operation will disengage the autopilot.
- CWS (control wheel steering) mode button on the pilot's stick. When pressed and held, it disengages the pitch, roll and pitch trim clutches allowing the pilot to maneuver the airplane by hand. Pressing the CWS button will also sync the autopilot ALT or VS commands to the actual altitude or vertical speed present at the time the button is released.

B. KCM 100 Configuration Module

The data which is specific to the DA 42 NG (for example: gain settings) is stored in the KCM 100 configuration module.

C. KS 271C Roll Servo

The roll servo is located behind the rear main bulkhead on the right side. It is mounted on a mounting plate which is made from sheet aluminum. Two aluminum clamps connect a bridle cable to the aileron push-rod.

D. KS 270C Pitch Servo

The pitch servo is located aft of the baggage compartment frame. It is mounted on a mounting plate which is made from sheet aluminum. Two aluminum clamps connect a bridle cable to the elevator push-rod.

E. KS 272C Pitch Trim Servo

The pitch trim servo is located under the co-pilot's seat. It is mounted on a mounting plate which is made from sheet aluminum and mounting bracket which is made from GFRP. Servo movement is transmitted to the trim wheel through a chain gear on the servo, a cardan shaft, and a chain gear next to the trim wheel on the right side.

Intentionally left blank.

Maintenance Practices

1. General

These Maintenance Practices tell you how to install the components of the KAP 140 autopilot system. They also tell you how to test and adjust the KAP 140 autopilot system.

2. Remove/Install the Flight Control Computer

A. Remove the Flight Control Computer

Detail Steps/Work Items		Key Items/References
(1)	Open the AUTOPILOT circuit breaker.	
(2)	Put a 3/32 Allen wrench into the access hole for the locking screw. Engage the screw.	
(3)	Turn the screw counter-clockwise until the unit disengages from the mounting rack.	
<p style="text-align: center;">CAUTION: DO NOT PULL ON THE KNOBS. DO NOT PRY THE FACE-PLATE. IF YOU PULL ON THE KNOBS, OR PRY THE FACE-PLATE, YOU CAN DAMAGE THE UNIT.</p> <p style="text-align: center;">CAUTION: DO NOT TOUCH THE CONNECTOR CARD AT THE REAR OF THE UNIT. THE ELECTROSTATIC CHARGE ON YOUR BODY CAN DAMAGE THE UNIT.</p>		
(4)	Pull gently on the sides of the unit to remove it from the mounting rack.	
(5)	Install the protective covers on the rear connectors of the flight control computer.	



B. Install the Flight Control Computer

Detail Steps/Work Items		Key Items/References
(1)	Remove the protective covers from the connectors on the replacement unit.	
(2)	Slide the unit into the rack. Engage the locking screw so that the latch front lobe touches the rack.	
(3)	Turn the locking screw clockwise so that the rear lobe engages the mounting rack.	
CAUTION: DO NOT OVER-TIGHTEN THE LOCKING SCREW. YOU CAN DAMAGE THE LOCKING MECHANISM.		
(4)	Continue to turn the screw until the unit is fully installed in the mounting rack.	
(5)	Close the AUTOPILOT circuit breaker.	
(6)	Check and adjust the servo "nulls".	Refer to the Installation Manual for the KAP 140 Flight Control System.
(7)	Do a test of the autopilot system: <ul style="list-style-type: none"> – Set the ELECT. MASTER switch to ON. – Set AV. MASTER switch to ON. – Observe selftest of the flight control computer. – Set AV. MASTER to OFF. – Set ELECT. MASTER switch to OFF. 	If no error message appears, the system is operative.

3. Remove/Install the KCM 100 Configuration Module

A. Remove the KCM 100 Configuration Module

Detail Steps/Work Items		Key Items/References
(1)	Open the AUTO PILOT circuit-breaker.	Instrument panel, right side.
(2)	Remove instrument panel cover.	Refer to Section 25-10 in the AMM.
(3)	Remove the KCM 100: <ul style="list-style-type: none">– Remove the two screws that attach the KCM 100 to the mounting rack.– Disconnect the electric cable.– Move the configuration module free of the instrument panel.	



B. Install the the KCM 100 Configuration Module

Detail Steps/Work Items		Key Items/References
<p>CAUTION: WHEN A NEW CONFIGURATION MODULE IS INSTALLED, YOU MUST MAKE SURE THAT IT HAS THE PART NUMBER WHICH IS SHOWN IN THE EQUIPMENT LIST IN CHAPTER 6 OF THE AIRPLANE FLIGHT MANUAL. IF A NEW CONFIGURATION MODULE IS INSTALLED, A COMPLETE CONFIGURATION PROCEDURE INCLUDING SOFTWARE UPLOAD IS NECESSARY.</p>		
(1)	Put the KCM 100 in place on the instrument panel. Connect the electric cable and engage the two locking screws.	
(2)	Install the instrument panel cover.	Refer to Section 25-10 in the AMM.
(3)	Close the AUTO PILOT circuit breaker.	Instrument panel, right side.
(4)	<p>Do a test of the autopilot system:</p> <ul style="list-style-type: none"> – Set the ELECT. MASTER switch to ON. – Set AV. MASTER switch to ON. – Observe self-test of the flight control computer. – Set AV. MASTER to OFF. – Set ELECT. MASTER switch to OFF. 	If no error message appears, the system is operative.

5. Remove/Install the Roll Servo

A. Remove the Roll Servo

Detail Steps/Work Items		Key Items/References
(1)	Remove the passengers seat.	Refer to Section 25-10 in the AMM.
(2)	Disconnect the connector from the servo.	
(3)	Remove the 2 screws which attach the servo to the mounting plate and the clutch.	Hold the servo.
(4)	Remove the servo clear of the airplane.	

B. Install the Roll Servo

Detail Steps/Work Items		Key Items/References
(1)	Put the servo in place on the mounting plate.	
(2)	Install the 2 screws which attach the servo to the mounting plate and clutch.	
(3)	Connect the connector to the servo.	
(4)	Do a test of the autopilot system: <ul style="list-style-type: none"> – Set ELECT. MASTER switch to ON. – Set AV. MASTER switch to ON. – Observe self-test of the flight control computer. – Set AV. MASTER switch to OFF. – Set ELECT. MASTER switch to OFF. 	If no error message appears, the system is operative.
(5)	Install the passengers seat.	Refer to Section 25-10 in the AMM.

6. Remove/Install the Roll Servo Clutch

A. Equipment

Item	Quantity	Part Number
Cable tension gauge.	1	Commercial.

B. Remove the Roll Servo Clutch

Detail Steps/Work Items		Key Items/References
(1)	Remove the roll servo.	Refer to Paragraph 5.
(2)	Release the clamps which connect the bridle cable to the aileron push-rod.	
(3)	Remove the bridle cable.	
(4)	Remove the 2 screws which attach the clutch to the mounting plate.	Hold the clutch.
(5)	Remove the clutch clear of the airplane.	

C. Install the Roll Servo Clutch

Detail Steps/Work Items		Key Items/References
(1)	Remove the pilot's seat or the co-pilot's seat.	Refer to Section 25-10 in the AMM to give access for the rigging pin.
(2)	Put the clutch in place on the mounting plate.	
(3)	Install the 2 screws which attach the clutch to the mounting plate.	
(4)	Center the aileron control system with a rigging pin at one control stick.	Refer to Section 27-10 in the AMM.
(5)	Center the capstan.	The recess for the ball in the middle of the bridle cable must be in the uppermost position.
(6)	Install bridle cable to capstan.	The ball in the middle of the bridle cable must engage in the recess on the capstan. Wrap bridle cable around capstan one turn to each side.
(7)	Connect the ends of the bridle cable to the aileron pushrod with the clamps.	Tighten clamps lightly to allow adjustment (see next step).
(8)	Using a small plastic hammer, move the clamps along the pushrod to adjust the bridle cable tension.	Adjust tension to 89 ±22 N (20 ±5 lbf). Measure cable tension with cable tension gauge.
(9)	Tighten the clamps.	
(10)	Remove the rigging pin from the control stick.	
(11)	Install the front seat which was removed.	Refer to Section 25-10 in the AMM.
(12)	Install the roll servo.	Refer to Paragraph 5.

7. Remove/Install the Pitch Servo

A. Remove the Pitch Servo

Detail Steps/Work Items		Key Items/References
(1)	Remove the trim/cover from the front face of the baggage compartment and remove the lower access panel from the baggage compartment insert.	
(2)	Disconnect the connector from the servo.	
(3)	Remove the 2 screws which attach the servo to the mounting plate and the clutch.	Hold the servo.
(4)	Remove the servo clear of the airplane.	

B. Install the Pitch Servo

Detail Steps/Work Items		Key Items/References
(1)	Put the servo in place on the mounting plate.	
(2)	Install the 2 screws which attach the servo to the mounting plate and clutch.	
(3)	Connect the connector to the servo.	
(4)	Do a test of the autopilot system: <ul style="list-style-type: none"> – Set ELECT. MASTER switch to ON. – Set AV. MASTER switch to ON. – Observe selftest of the flight control computer. – Set AV. MASTER switch to OFF. – Set ELECT. MASTER to OFF. 	If no error message appears, the system is operative.
(5)	Install the baggage compartment lower access panel and install the trim/cover to the front face of the baggage compartment.	

8. Remove/Install the Pitch Servo Clutch

A. Equipment

Item	Quantity	Part Number
Cable tension gauge.	1	Commercial.

B. Remove the Pitch Servo Clutch

Detail Steps/Work Items		Key Items/References
(1)	Remove the pitch servo.	Refer to Paragraph 7.
(2)	Release the clamps which connect the bridle cable to the elevator pushrod.	
(3)	Remove the bridle cable.	
(4)	Remove the 2 screws which attach the clutch to the mounting plate.	Hold the clutch.
(5)	Remove the clutch from the airplane.	

C. Install the Pitch Servo Clutch

Detail Steps/Work Items		Key Items/References
(1)	Remove the pilot's seat or the co-pilot's seat.	Refer to Section 25-10 in the AMM to give access for the rigging pin.
(2)	Put the clutch in place on the mounting plate.	
(3)	Install the 2 screws which attach the clutch to the mounting plate.	
(4)	Center the elevator control system with a rigging pin at one control stick.	Refer to Section 27-30 in the AMM.
(5)	Center the capstan.	The recess for the ball in the middle of the bridle cable must be in the uppermost position.
(6)	Install bridle cable to capstan.	The ball in the middle of the bridle cable must engage in the recess on the capstan. Wrap bridle cable around capstan one turn to each side.
(7)	Connect the ends of the bridle cable to the elevator push-rod with the clamps.	Tighten clamps lightly to allow adjustment (see next step).
(8)	Using a small plastic hammer, move the clamps along the push-rod to adjust the bridle cable tension.	Adjust tension to 89 ± 22 N (20 ± 5 lbf). Measure cable tension with cable tension gauge.
(9)	Tighten the clamps.	
(10)	Remove the rigging pin from the control stick.	
(11)	Install the front seat which was removed.	Refer to Section 25-10 in the AMM.
(12)	Install the pitch servo.	Refer to Paragraph 7.

9. Remove/Install the Pitch Trim Servo

A. Remove the Pitch Trim Servo

Detail Steps/Work Items		Key Items/References
(1)	Remove the co-pilot's seat.	Refer to Section 25-10 in the AMM.
(2)	Dis-connect the connector from the servo.	
(3)	Remove the 2 screws which attach the servo to the mounting plate and the clutch.	Hold the servo.
(4)	Remove the servo clear of the airplane.	

B. Install the Pitch Trim Servo

Detail Steps/Work Items		Key Items/References
(1)	Put the servo in place on the mounting plate.	
(2)	Install the 2 screws which attach the servo to the mounting plate and clutch.	The upper forward screw also holds the chain adjuster. Ensure proper chain tension.
(3)	Connect the connector to the servo.	
(4)	Do a test of the autopilot system: <ul style="list-style-type: none"> – Set ELECT MASTER switch to ON. – Set AVIONICS MASTER switch to ON. – Observe self-test of the flight control computer. – Set AVIONICS MASTER switch to OFF. – Set ELECT MASTER switch to OFF. 	If no error message appears, the system is operative.
(5)	Install the co-pilot's seat.	Refer to Section 25-10 in the AMM.



10. Remove/Install the Pitch Trim Servo Clutch

A. Remove the Pitch Trim Servo Clutch

Detail Steps/Work Items		Key Items/References
<p>CAUTION: DO NOT APPLY STRONG FORCES TO THE CARDAN SHAFT. THE UPPER CARDAN JOINT CONNECTS TO A PART WHICH IS WEAK BY DESIGN TO GIVE OCCUPANT PROTECTION IN AN EMERGENCY LANDING.</p>		
(1)	Remove the pitch trim servo.	Refer to Paragraph 9.
(2)	Remove the screw which holds the cap to the capstan.	
(3)	Remove the cap from the capstan.	
(4)	Release chain tension with chain adjuster.	On the chain gear next to the servo.
(5)	Remove the chain from the chain gear.	
(6)	Remove the 2 screws which attach the clutch and the chain adjuster to the mounting plate.	Hold the clutch and the chain adjuster.

B. Install the Pitch Trim Servo Clutch

Detail Steps/Work Items		Key Items/References
(1)	Put the clutch and the chain adjuster in place on the mounting plate.	
(2)	Install the 2 screws which attach the clutch and the chain adjuster to the mounting plate.	
(3)	Install the chain to the chain gear.	
(4)	Put the cap in place on the capstan.	
(5)	Install the screw which holds the cap to the capstan.	
(6)	Install the pitch trim servo.	Refer to Paragraph 9.

11. Adjust the Bridle Cable Tension

A. Equipment

Item	Quantity	Part Number
Cable tension gauge.	1	Commercial.

B. Adjustment Procedure

	Detail Steps/Work Items	Key Items/References
(1)	Loosen the bolts in the clamps which connect the bridle cable to the pushrod.	Do not remove the bolts. Loosen just enough so that the next step can be done.
(2)	Using a small plastic hammer, move the clamps along the pushrod to adjust the bridle cable tension.	Adjust tension to 89 ± 22 N (20 ± 5 lbf). Measure cable tension with cable tension gauge.
(3)	Tighten the bolts in the clamps which connect the bridle cable to the pushrod.	

12. Adjust the Servo Clutch Torques

A. Equipment

Item	Quantity	Part Number
Goodrich slip clutch test stand.	1	20-9855-03.

B. Adjustment Procedure

	Detail Steps/Work Items	Key Items/References
(1)	Remove the clutch from the airplane.	Refer to this Section.
(2)	Install the clutch assembly on the slip clutch test stand.	Refer to the equipment manufacturers' documentation.
(3)	Measure clockwise (CW) and counterclockwise (CCW) clutch torque, adjust if necessary.	Refer to the equipment manufacturers' documentation. The correct clutch torques are: Roll servo 2.03 ±0.23 Nm (18 ±2 lbf.in.) Pitch servo 3.39 ±0.34 Nm (30 ±3 lbf.in.) Pitch trim servo 4.07 ± 0.45 Nm (36 ±4 lbf.in.)
(4)	Remove the clutch assembly from the slip clutch test stand.	
(5)	Install the clutch to the airplane.	Refer to this Section.

13. Mechanical Test of the Autopilot System

Do this check at the intervals given in Section 05-10.

	Detail Steps/Work Items	Key Items/References
(1)	Check bridle cable tension for the roll servo, adjust if necessary.	Refer to this Section.
(2)	Check bridle cable tension for the pitch servo, adjust if necessary.	Refer to this Section.
(3)	Check the clutch torque settings for the roll servo, adjust if necessary.	Refer to this Section.
(4)	Check the clutch torque settings for the pitch servo, adjust if necessary.	Refer to this Section.
(5)	Check the clutch torque settings for the pitch trim servo, adjust if necessary.	Refer to this Section.
(6)	Perform Pitot and static system leak tests.	Refer to Section 34-10 in the AMM.

Intentionally left blank.

CHAPTER 31 – INDICATING SYSTEMS
Section 31-10 – Instrument and Control Panels

2. Instrument Panel Description

The landing gear and flap control switches are located on each side of the autopilot control panel, if the KAP 140 autopilot is installed.

Intentionally left blank.

CHAPTER 52 – DOORS

Section 52-10 – Canopy and Passenger Door

2. Canopy Description and Operation

Figure 1 shows the canopy locking mechanism if MÅM 42-097 is not carried out.

A handle on the left of the canopy operates two locking bolts. The handle has a spring assisted over-center lock which holds the handle in the closed position. The locking bolts are at the bottom rear corners of the canopy.

The handle has two parts. The inner handle is black and has a double lever. The outer handle is red and attaches to the inner handle with two roll pins. A connecting rod attaches to the rear of the double lever. The other end of the connecting rod attaches to the inside of the left locking bolt.

A teleflex cable attaches to the front of the double lever. The teleflex cable goes inside the front of the canopy frame to the right locking bolt. If you pull the canopy handle away from the canopy frame, these things happen:

- The double lever turns to pull the connecting rod and the teleflex cable.
- The connecting rod pulls the left locking bolt forward.
- The teleflex cable pulls the right locking bolt forward. The forward movement of the locking bolt operates the door unlocked warning micro-switch in the left side fuselage shell.

The canopy can be pushed up and forward to open.

With the canopy fully closed, push the canopy handle towards the canopy frame. This engages the locking bolts in the fuselage holes. The spring assisted over-center lock holds the handle in the closed position. The right locking bolt operates the micro-switch for the DOOR warning caption. When the handle is flush with the canopy frame, the canopy is locked. Push up on the rear of the canopy frame to make sure that it is locked. A key operated lock can be used to secure the canopy in the closed position when the airplane is parked.

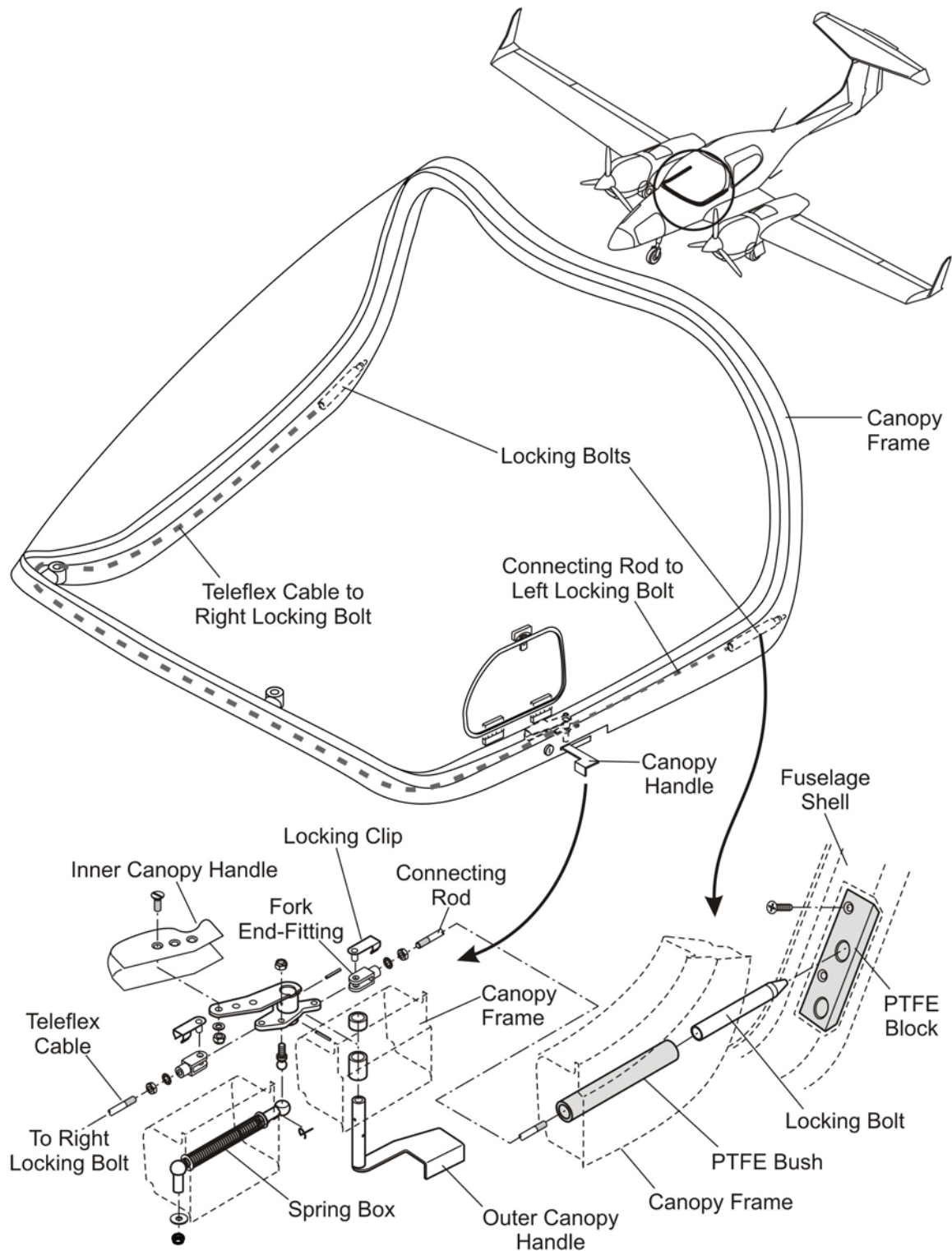

Figure 1: Canopy Locking Mechanism, MAM 42-097 Not Carried Out

3. Passenger Door Description and Operation

Figure 2 shows the passenger door installation and locking mechanism if MÄM 42-097 is not carried out.

The passenger door is a CFRP molding with inner and outer frames. The frames bond together with thickened resin. Each part of the frame has layers of carbon cloth and one layer of glass cloth. Areas of high stress have extra layers of carbon cloth. Mounting bushes for the handle and locking bolts bond to the inside of the frame with thickened resin.

The door has a acrylic glass window. A special flexible adhesive bonds the window to the door frame. A flexible filler seals the small gap between the edge of the window and the frame.

Two hinges attach the door to the top of the fuselage near the center-line. The hinges bolt to the door frame. The front hinge can be removed from inside of the cabin in an emergency. With the front hinge removed, the passenger door can be forced open from the top. A gas strut attaches to a bracket at the rear of the door and to the fuselage. The gas strut holds the door open. A door unlocked warning caption on the ICS display operates when the door is unlocked.

A handle on the left of the door operates two locking bolts. The locking bolts are at the bottom front and rear corners of the door.

The handle has two parts. The inner handle is black and has a double lever. The outer handle is red and attaches to the inner handle with two roll pins. A long connecting rod attaches to the rear of the double lever. The other end of the long connecting rod attaches to the inside of the rear locking bolt. A safety lock is fitted to prevent accidental movement of the handle.

You must lift the safety handle before you can operate the black handle from inside the passenger compartment. To operate the red handle from the outside you must push the button next to the red handle to lift the inner safety lock.

A short connecting rod attaches to the front of the double lever. The short connecting rod goes to the front locking bolt. If you pull the canopy handle away from the canopy frame, these things happen:

- The double lever turns to pull the both of the connecting rods.
- The long connecting rod pulls the rear locking bolt forward.
- The short connecting bolt pulls the front locking bolt aft. The aft movement of the locking bolt operates a micro switch for the warning caption located on the ICS.

The door can be pushed up and out to open.

With the door fully closed, push the door handle towards the door frame. This engages the locking bolts in the fuselage holes. The forward locking bolt operates the door unlocked micro switch. When the handle is flush with the door frame, the door is locked. Push outwards on the bottom of the door frame to make sure that it is locked. A key operated lock can be used to secure the door in the closed position when the airplane is parked.

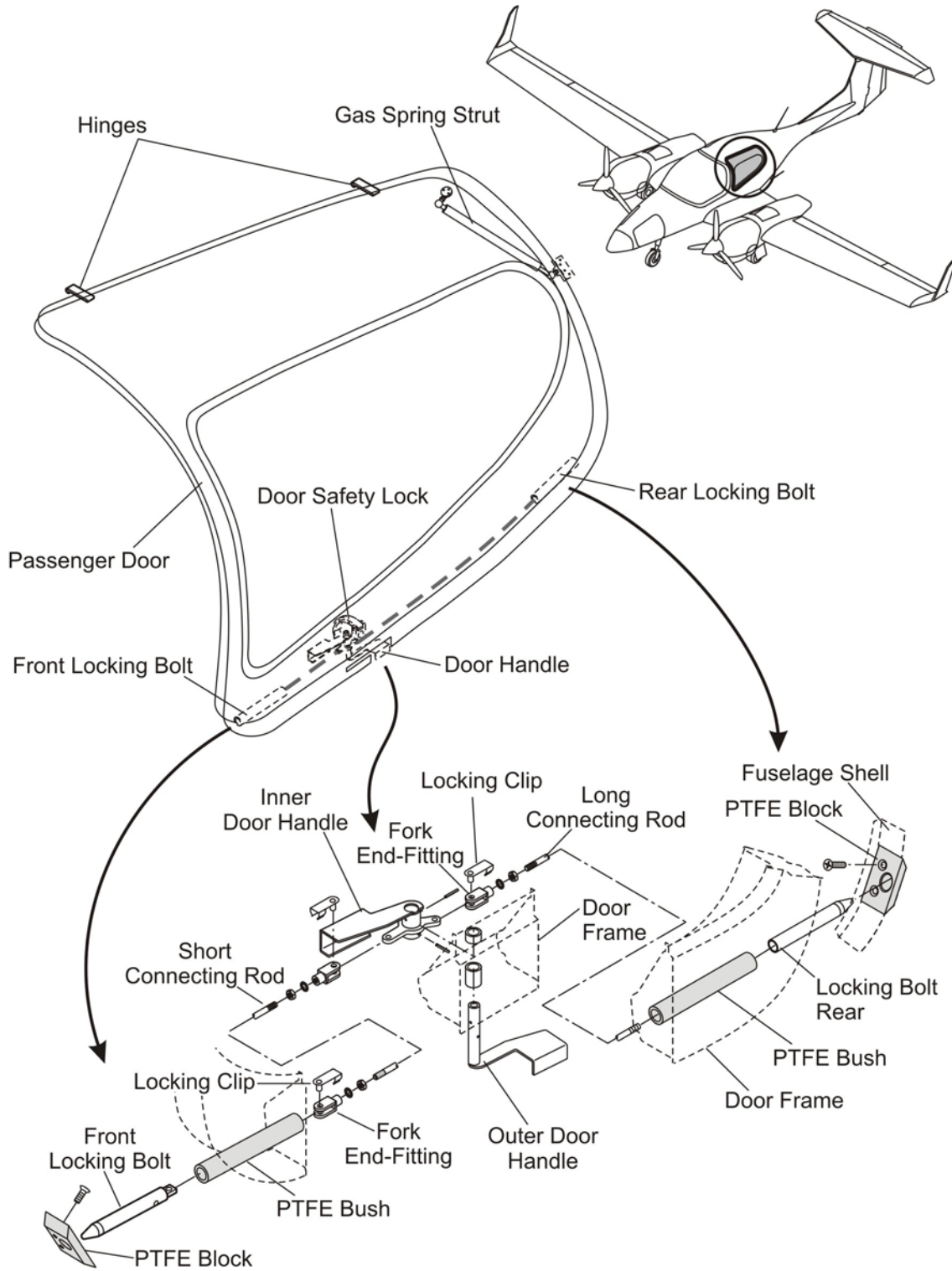

Figure 2: Passenger Door, MÄM 42-097 Not Carried Out

Intentionally left blank.

CHAPTER 92 – WIRING DIAGRAMS

1. General

Title	Drawing No.	Rev. No.	No. of Sheets
Schematic, KAP 140 Wiring	D64-9222-10-01	-	1
Schematic, G 1000	D64-9231-60-02	-	6
Schematic, LH ECU	D64-9277-40-02x01	-	2
Schematic, RH ECU	D64-9277-40-03x01	-	2

Intentionally left blank.

REV	SH	ZONE	DESCRIPTION	DATE	APPROVAL
-	01	ALL	OAM 42-17 FIRST RELEASE	18.05.09	SEE TB

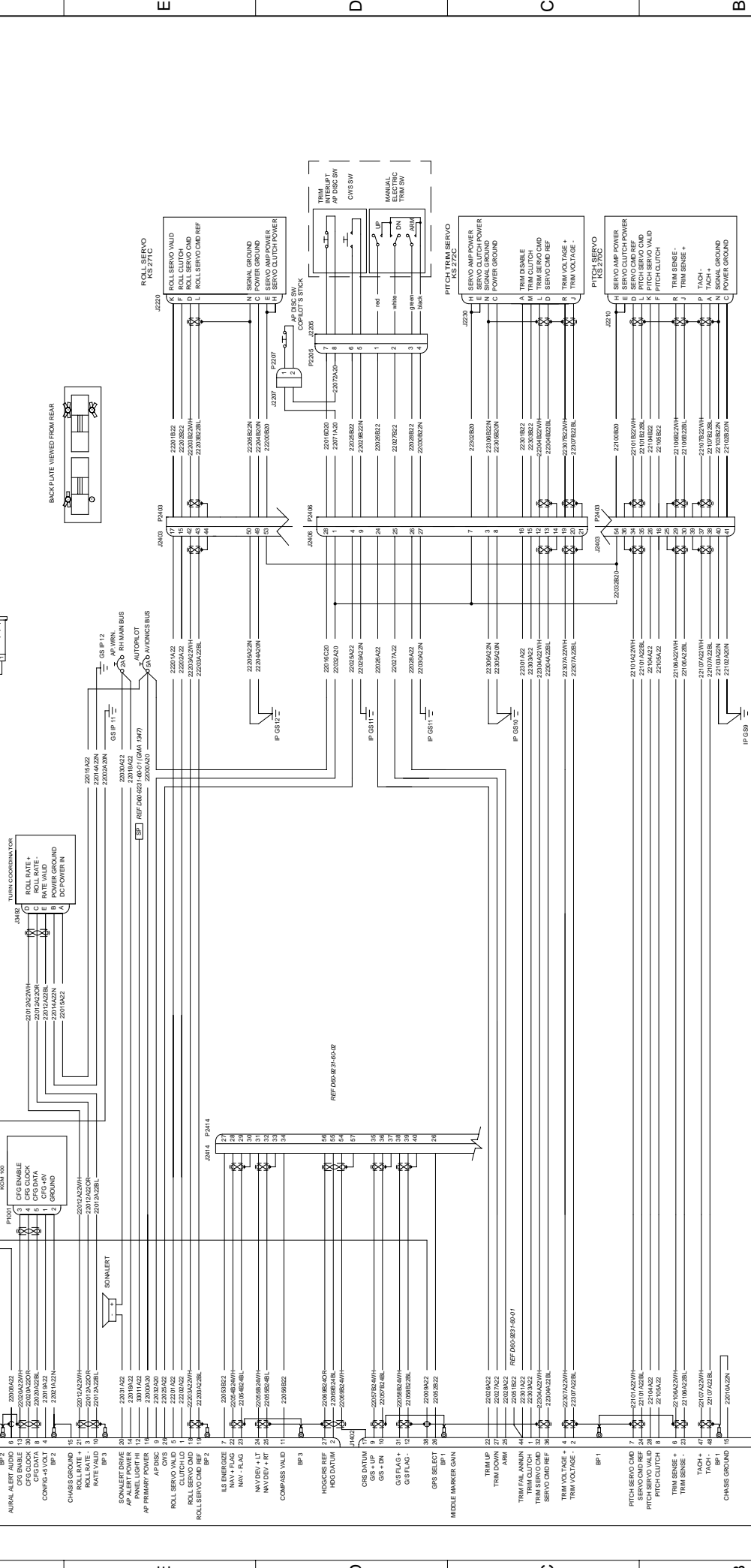

Diamond Aircraft Industries Industries GmbH		PROJECT: DA 42 NG TITLE: Schematic, KAP 140 Wiring
DEPARTMENT: DRAWN: Moise	SIGN:	DATE: 18.05.09
CHECKED: Kowatsch		
QA: N/A		
STRESS: N/A		
MANUF.: N/A		
SYSTEM: N/A		
APPROVED: Zeilinger		

IDENTIFICATION MARKINGS: DE-S-10-0003	CLASSIFICATION: NONE
INTERCHANGEABLE PART: NO	THIS DRAWING WAS PRODUCED USING: SOFTWARE: SOLID EDGE V18
UNLESS OTHERWISE SPECIFIED DIMENSIONS ARE IN MM	FINISH IN MICRO-METER
DIMENSION TOLERANCES: 3.2	ANGLE: ±0.25
	DECIMAL: ±0.5
	ANGLE: ±1°
	RAD: ±0.5

DWG. NO. DAIA D64-9222-10-01	REV. -
CODE: 710197	SCALE: NTS
SH: 01	OF: 01

REV		SH	ZONE	DESCRIPTION	DATE	APPROVAL
-		ALL	ALL	OAM 42-171 FIRST RELEASE	15.05.09	SEE TB

NOTES:

- UNLESS OTHERWISE NOTED, ALL STRANDED WIRE MUST CONFORM TO MIL-W-22759/16 OR EQUIVALENT
- UNLESS OTHERWISE NOTED, ALL SHIELDED WIRE MUST CONFORM TO MIL-C-27500 OR EQUIVALENT
- UNLESS OTHERWISE NOTED, ALL WIRES ARE 24 GAUGE MINIMUM.
- SYMBOL DESIGNATIONS
 - TWISTED SHIELDED SINGLE CONDUCTOR SHIELD TERMINATED TO GROUND
 - TWISTED SHIELDED SINGLE CONDUCTOR SHIELD FLOATS
 - TWISTED SHIELDED PAIR SHIELD TERMINATED TO GROUND
 - TWISTED SHIELDED PAIR SHIELD FLOATS
 - TWISTED SHIELDED 3 CONDUCTOR SHIELD TERMINATED TO GROUND
 - TWISTED SHIELDED 3 CONDUCTOR SHIELD FLOATS
- UNLESS OTHERWISE NOTED, ALL SHIELD GROUNDS MUST BE MADE TO THE RESPECTIVE UNIT BACKSHELLS. ALL OTHER GROUNDS SHOULD BE TERMINATED TO AIRCRAFT GROUND AS CLOSE TO THE RESPECTIVE UNIT AS POSSIBLE.
- USE AIRCRAFT GRADE CATEGORY 5 ETHERNET CABLE.

MANUFACTURER	P/N
PIC WIRE AND CABLE	E 10427 (27 GAUGE)
PIC WIRE AND CABLE	E 10424 (24 GAUGE)
ELECTRONIC CABLE SPECIALIST	392404 (24 GAUGE)
- INSTALLATION INSTRUCTIONS FOR OAT PROBE, GMU44, GND HARNESS, CONFIGURATION MODULES, AND THERMOCOUPLES.

DESCRIPTION	DRAWING NUMBER
INSTR SHEET, OAT PROBE	190-0031-3-00
INSTR SHEET, GMU44	190-0031-3-04
INSTR SHEET, CONFIG MODULE	190-0031-3-02
INSTR SHEET, THERMOCOUPLE	190-0031-3-01
- FOR FAN FAIL OUTPUT: OPEN = ACTIVE = FAN FAIL, GROUND = INACTIVE = FAN OK
- FOR TRIM FAIL OUTPUT: GROUND = ACTIVE = TRIM FAIL, OPEN = INACTIVE = TRIM OK
- RELATED DOCUMENTS
 - 190-0031-3-00 UNIT INTERCONNECT SUMMARY.
 - 190-00295-28 UNIT POWER.
 - 190-00295-29 INTERCONNECT.
- FOR GROUNDING PROCEDURE REFER TO GARMIN DOCUMENTS 190-00815-00 AND 190-0031-3-04. ADDITIONAL FOR IFR OPERATION, REFER TO GARMIN DOCUMENT 190-0031-3-08.
- NOTE THE FOLLOWING PIN DIFFERENCES IN REV 2 AND REV 3 GIA P803:

PIN NAME	REV 2 PIN	REV 3 PIN
CAN BUS 1 TERMINATION	35	34
CAN BUS 2 HI	29	32

REV 2 UNITS HAVE SERIAL NUMBERS LESS THAN 46801600
REV 3 UNITS HAVE SERIAL NUMBERS OF 46801600 OR GREATER

DIMENSIONS		METRIC	IDENTIFICATION MARKINGS	
FIRST ANGLE PROJECTION		FORMAT A3	DE-S-10-00003	
UNLESS OTHERWISE SPECIFIED DIMENSIONS ARE IN MM			CLASSIFICATION: NONE	
DIMENSION TOLERANCES		3.2	INTERCHANGEABLE PART	NO
2 DECIMAL ±0.25			THIS DRAWING WAS PRODUCED USING	
1 DECIMAL ±0.5			SOFTWARE: SOLID EDGE V18	
DECIMAL ANGLE ±1°			FILENAME	
RAD ±0.5			D64-9231-60-02.dft	

Diamond Aircraft Industries		N. A. Otto-Straße 5 A-2700 Wiener Neustadt	
DEPARTMENT	SIGN	PROJECT	TITLE
DRAWN: Moise		DA 42 NG	Schematic, G1000
CHECKED: Kowatsch			
QA: N/A			
STRESS: N/A			
MANUF.: N/A			
SYSTEM: N/A			
APPROVED: Zeilinger			

REV	DWG. NO.	SH	OF
-	DAIA D64-9231-60-02	01	06

CODE	SCALE	1:1
710197	1:1	

ALL RIGHTS RESERVED FOR THIS DOCUMENT WHICH MAY NOT BE REPRODUCED OR DISCLOSED TO THIRD PARTIES WITHOUT THE PRIOR WRITTEN CONSENT OF DIAMOND AIRCRAFT INDUSTRIES

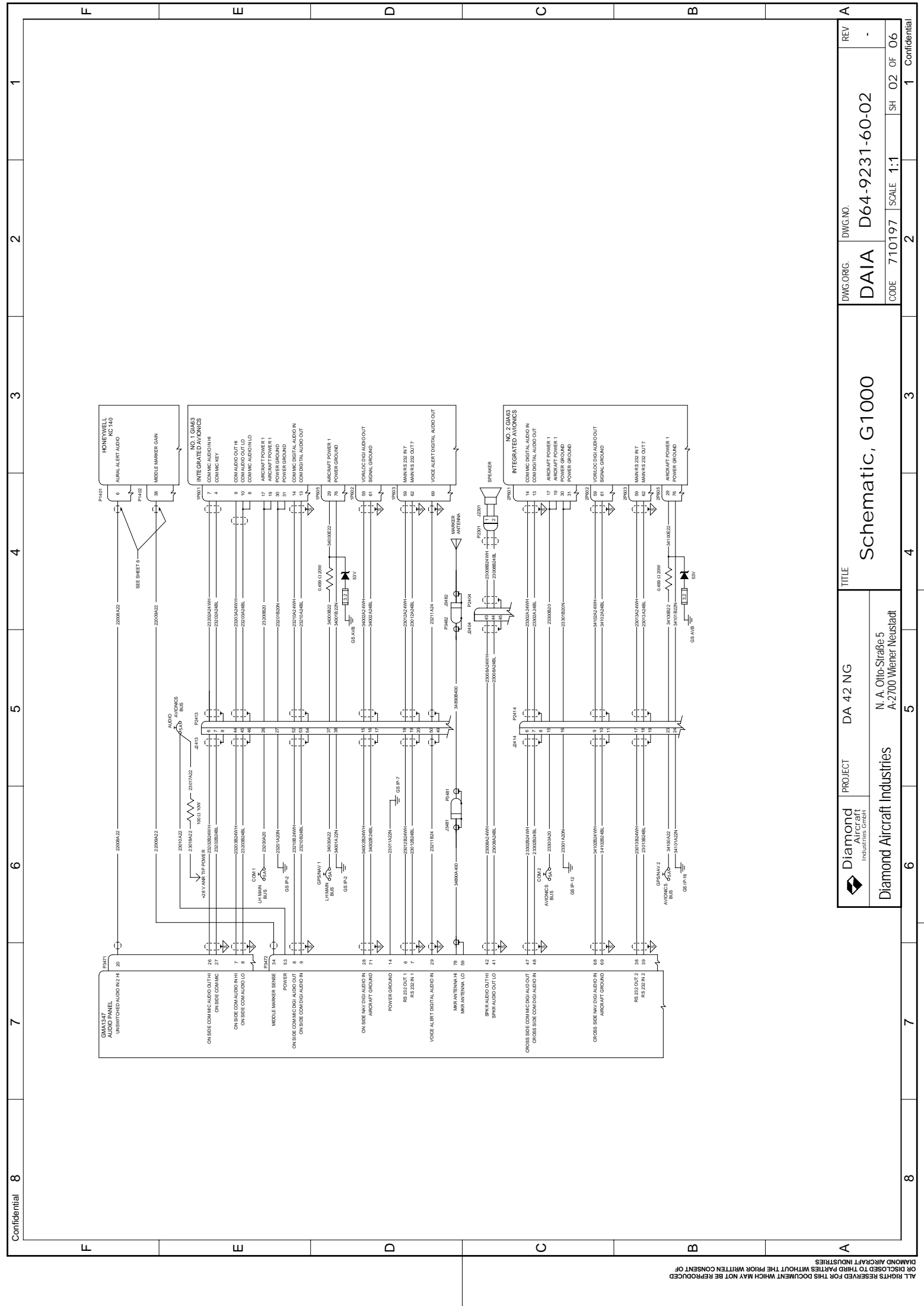

REV	-	DWG. NO.	D64-9231-60-02	SH	02	OF	06
	DWG. ORIG.		DAIA		CODE		710197
TITLE			Schematic, G1000				
PROJECT		DA 42 NG		3			
INDUSTRY		Diamond Aircraft Industries GmbH		4			
ADDRESS		N. A. Otto-Straße 5 A-2700 Wiener Neustadt		5			
SCALE		1:1		6			
SHEET		1		7			
TOTAL SHEETS		1		8			

ALL RIGHTS RESERVED FOR THIS DOCUMENT WITHOUT THE PRIOR WRITTEN CONSENT OF DIAMOND AIRCRAFT INDUSTRIES

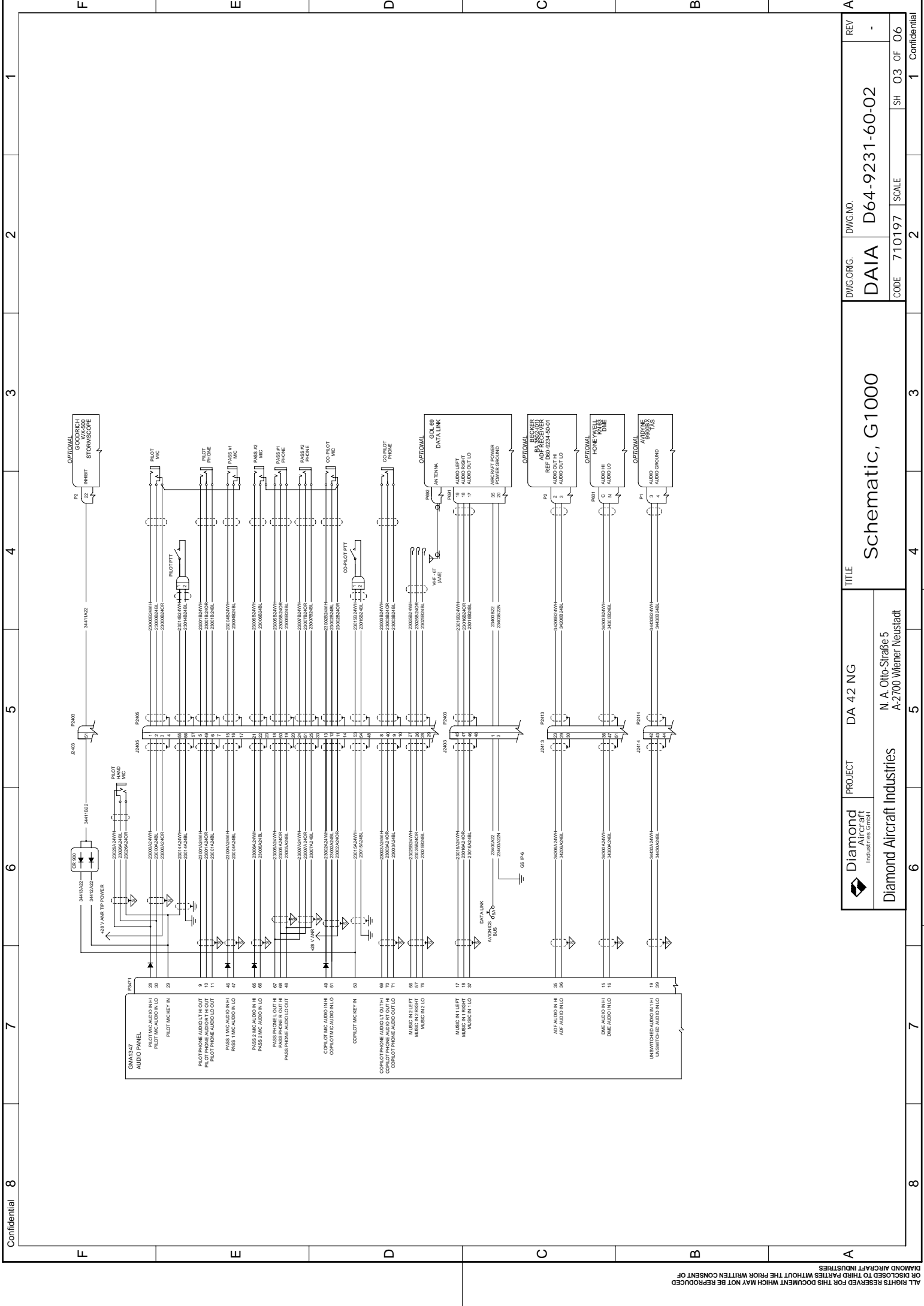

Confidential 8 7 6 5 4 3 2 1

PROJECT		DA 42 NG		TITLE		Schematic, G1000		DWG. NO.		D64-9231-60-02		REV		-	
Diamond Aircraft Industries GmbH		Diamond Aircraft Industries		N. A. Otto-Straße 5 A-2700 Wiener Neustadt		DAIA		CODE		710197		SCALE		1	
6		5		4		3		2		1		SH		03 OF 06	
8		7		6		5		4		3		2		1	
F		E		D		C		B		A		CONFIDENTIAL			

ALL RIGHTS RESERVED FOR THIS DOCUMENT WHICH MAY NOT BE REPRODUCED OR DISCLOSED TO THIRD PARTIES WITHOUT THE PRIOR WRITTEN CONSENT OF DIAMOND AIRCRAFT INDUSTRIES

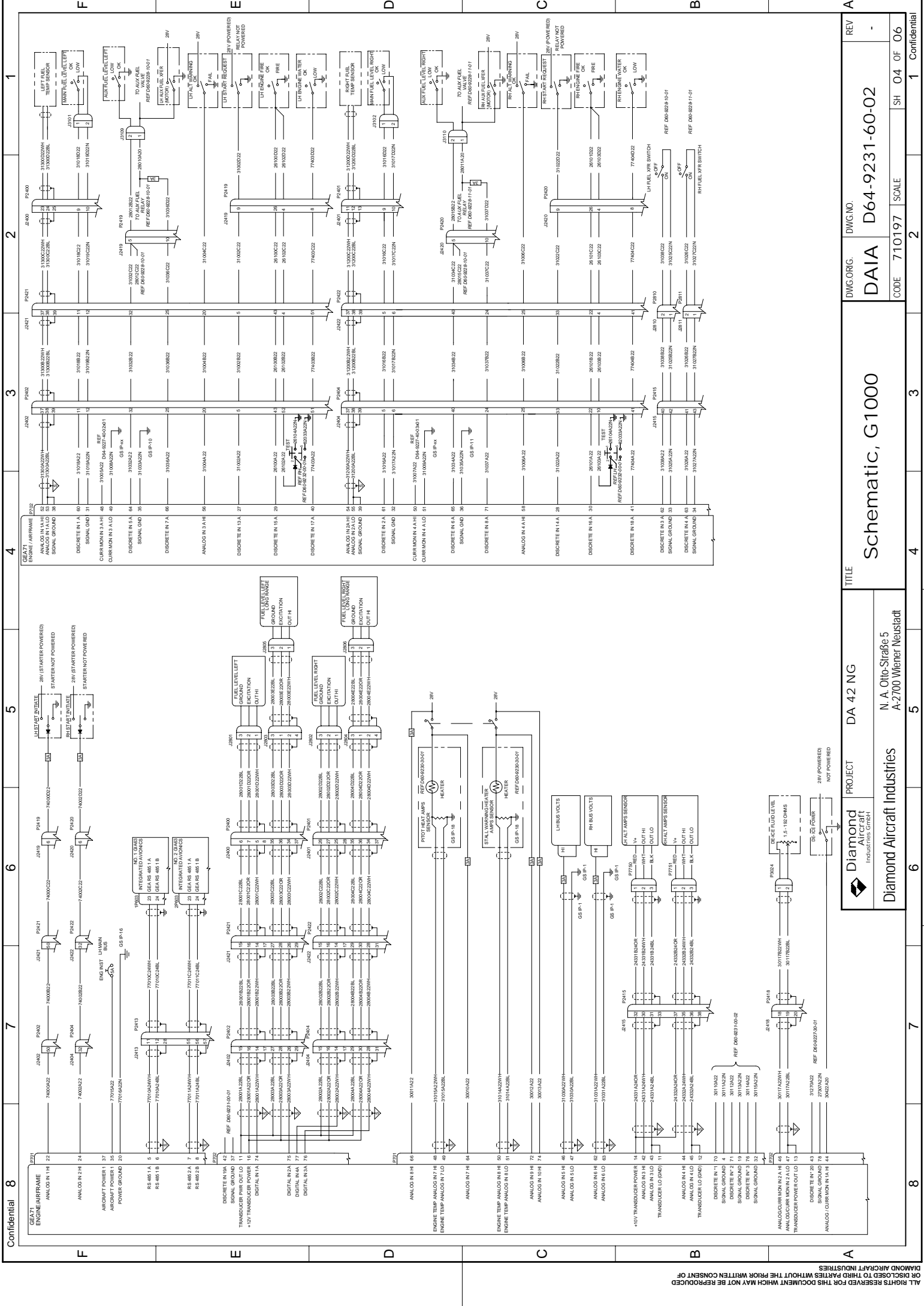

Confidential 8

7

6

5

4

3

2

1

F

REV	-
DWG. NO.	D64-9231-60-02
DAIA	DAIA
CODE	710197
SCALE	2
SH	04 OF 06
1	Confidential

Schematic, G1000

TITLE
 DA 42 NG
 PROJECT
 Diamond Aircraft Industries GmbH
 N. A. Otto-Straße 5
 A-2700 Wiener Neustadt

8
 7
 6
 5
 4
 3
 2
 1

ALL RIGHTS RESERVED FOR THIS DOCUMENT WHICH MAY NOT BE REPRODUCED OR DISCLOSED TO THIRD PARTIES WITHOUT THE PRIOR WRITTEN CONSENT OF DIAMOND AIRCRAFT INDUSTRIES

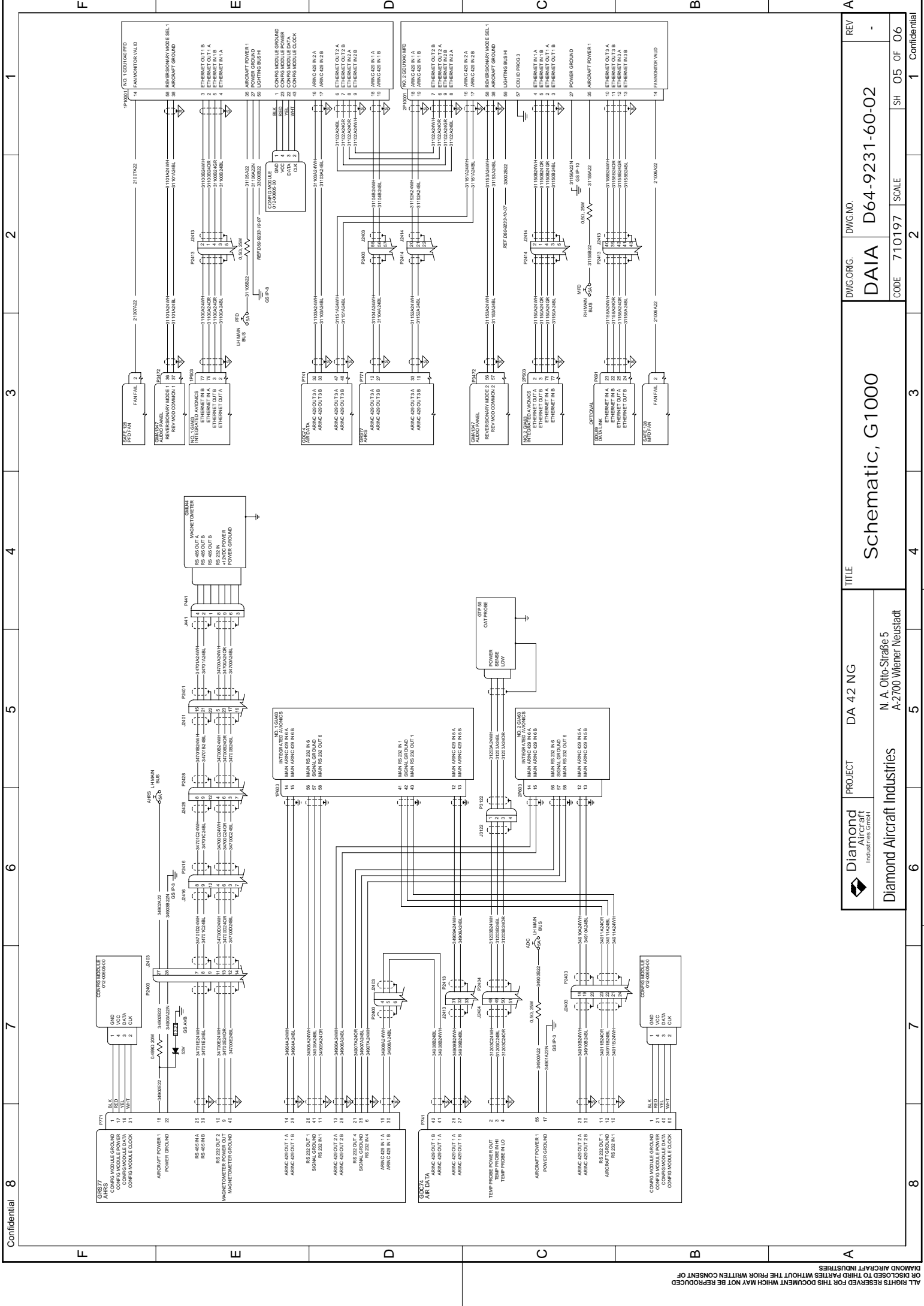

REV	DWG. NO.	DAIA	D64-9231-60-02
SH 05 OF 06	SCALE	1	Confidential

Schematic, G1000

PROJECT	DA 42 NG
TITLE	Schematic, G1000
REV	-

PROJECT	DA 42 NG
TITLE	Schematic, G1000
REV	-
DAIA	D64-9231-60-02
SCALE	1
SH	05 OF 06
CONFIDENTIAL	

ALL RIGHTS RESERVED FOR THIS DOCUMENT WHICH MAY NOT BE REPRODUCED OR DISCLOSED TO THIRD PARTIES WITHOUT THE PRIOR WRITTEN CONSENT OF DIAMOND AIRCRAFT INDUSTRIES

8	7	6	5	4	3	2	1
CONFIDENTIAL		REVISION		DATE		APPROVAL	
REV		SH		ZONE		DESCRIPTION	
-		ALL		ALL		OAM 42-17 FIRST RELEASE	
						13.05.09	
						SEE TB	

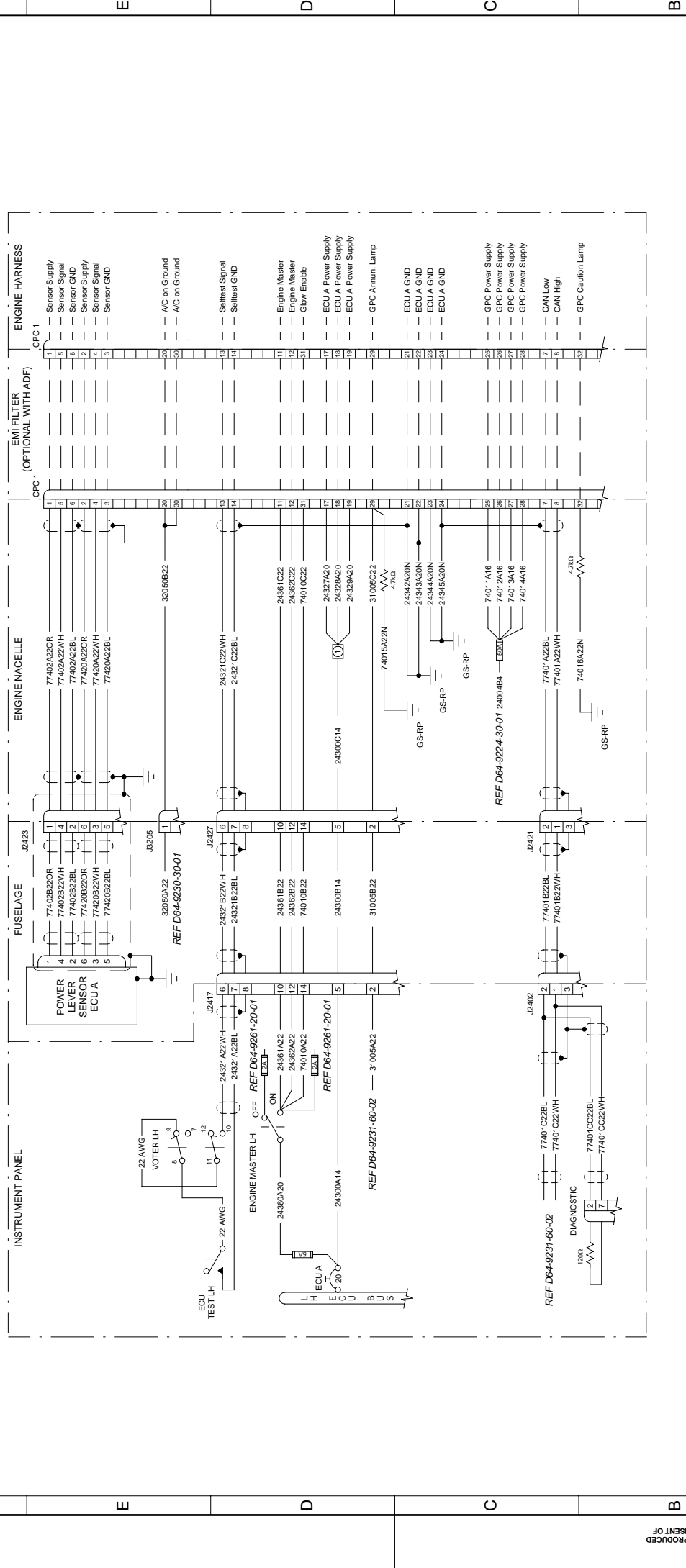

DIAMOND AIRCRAFT INDUSTRIES		N. A. Otto-Straße 5 A-2700 Wiener Neustadt	
DEPARTMENT		PROJECT	
DRAWN		DA 42 NG	
CHECKED:		TITLE	
KOWATRSCH		Schematic, LH ECU	
DATE		DATE	
13.05.09		13.05.09	
SIGN		SCALE	
		NTS	
DWG. NO.		DWG. NO.	
DAIA		D64-9277-40-02X01	
CODE		SH	
710197		01 OF 02	
APPROVED: Zeilinger		1 Confidential	

8	7	6	5	4	3	2	1
---	---	---	---	---	---	---	---

ALL RIGHTS RESERVED FOR THIS DOCUMENT WHICH MAY NOT BE REPRODUCED OR DISCLOSED TO THIRD PARTIES WITHOUT THE PRIOR WRITTEN CONSENT OF DIAMOND AIRCRAFT INDUSTRIES

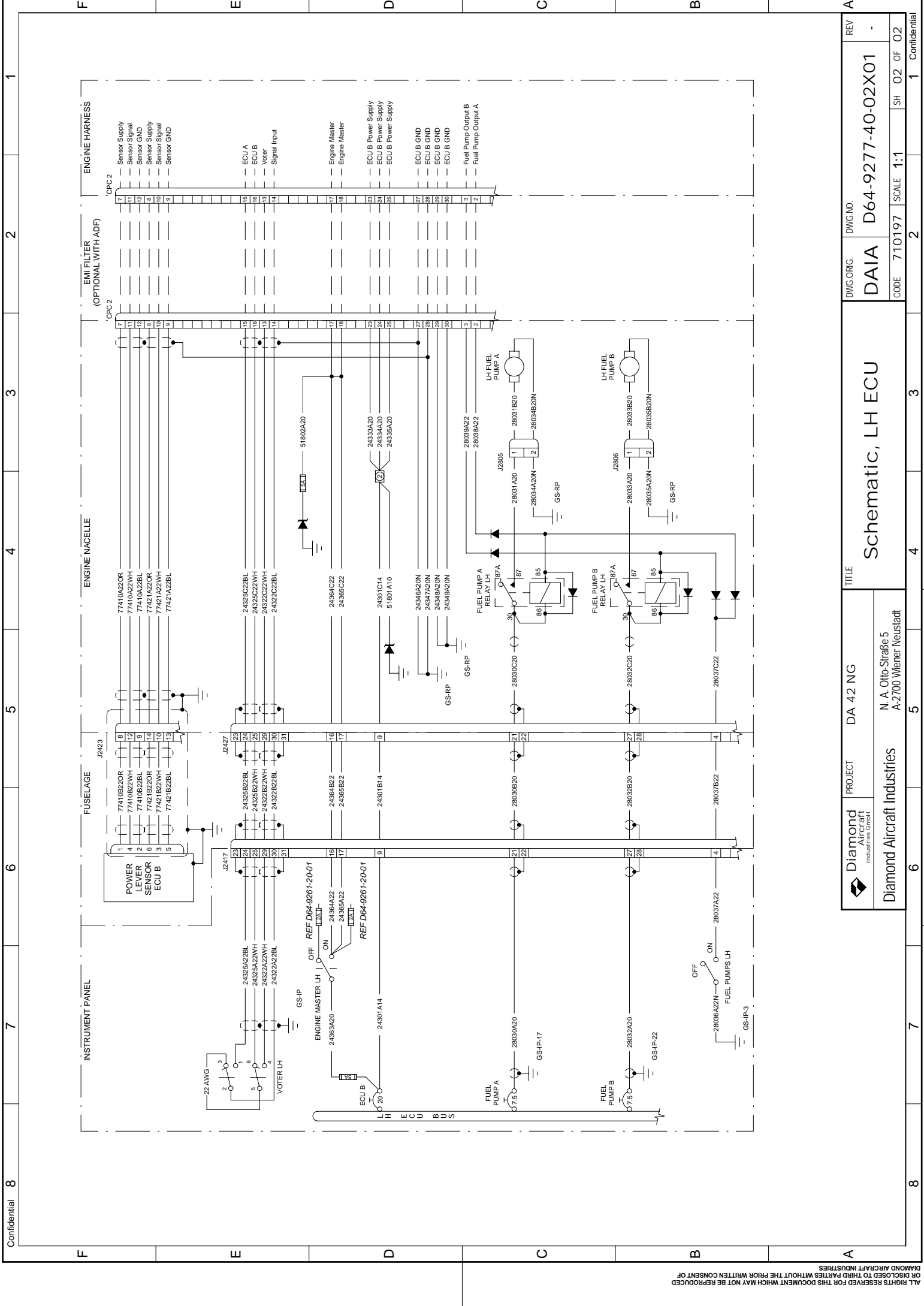

Confidential 8 7 6 5 4 3 2 1

		PROJECT	DA 42 NG	TITLE	Schematic, LH ECU			DWG.NO.	D64-9277-40-02X01	REV	-
Diamond Aircraft Industries GmbH Diamond Aircraft Industries N. A. Otto-Straße 5 A-2700 Wiener Neustadt								CODE	710197	SCALE	1:1
									2		SH 02 OF 02
									3		1 Confidential

ALL RIGHTS RESERVED FOR THIS DOCUMENT WHICH MAY NOT BE REPRODUCED OR DISCLOSED TO THIRD PARTIES WITHOUT THE PRIOR WRITTEN CONSENT OF DIAMOND AIRCRAFT INDUSTRIES

REV	SH	ZONE	DESCRIPTION	DATE	APPROVAL
.	ALL	ALL	OAM 42-17 FIRST RELEASE	13.05.09	SEE TB

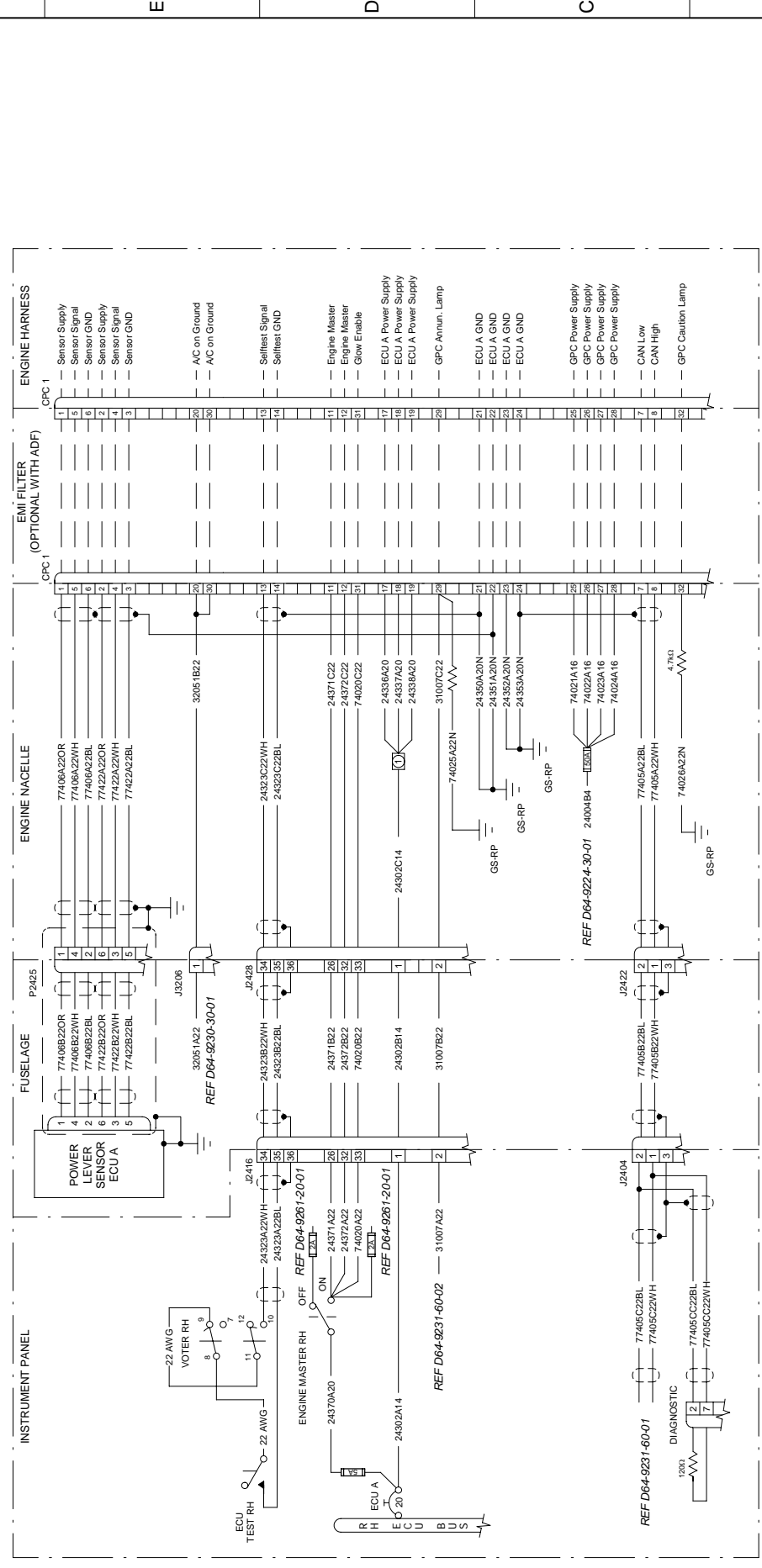

DEPARTMENT	SIGN	DATE	PROJECT
Diamond Aircraft Industries GmbH		13.05.09	DA 42 NG

IDENTIFICATION MARKINGS	CLASSIFICATION	INTERCHANGEABLE PART	NO
DE-S-10-00003	NONE	THIS DRAWING WAS PRODUCED USING	NO

DIMENSIONS	METRIC	FORMAT	FINISH
FIRST ANGLE PROJECTION	A3	3.2	IN MICRO-METER

DIMENSION TOLERANCES	UNLESS OTHERWISE SPECIFIED DIMENSIONS ARE IN MM	FILENAME	APPROVED:
2 DECIMAL ±0.25 1 DECIMAL ±0.5 DECIMAL ±1 ANGLE ±1° RAD ±0.5	3.2	D64-9277-40-03X01.dft	Zellinger

ALL RIGHTS RESERVED FOR THIS DOCUMENT WHICH MAY NOT BE REPRODUCED OR DISCLOSED TO THIRD PARTIES WITHOUT THE PRIOR WRITTEN CONSENT OF DIAMOND AIRCRAFT INDUSTRIES

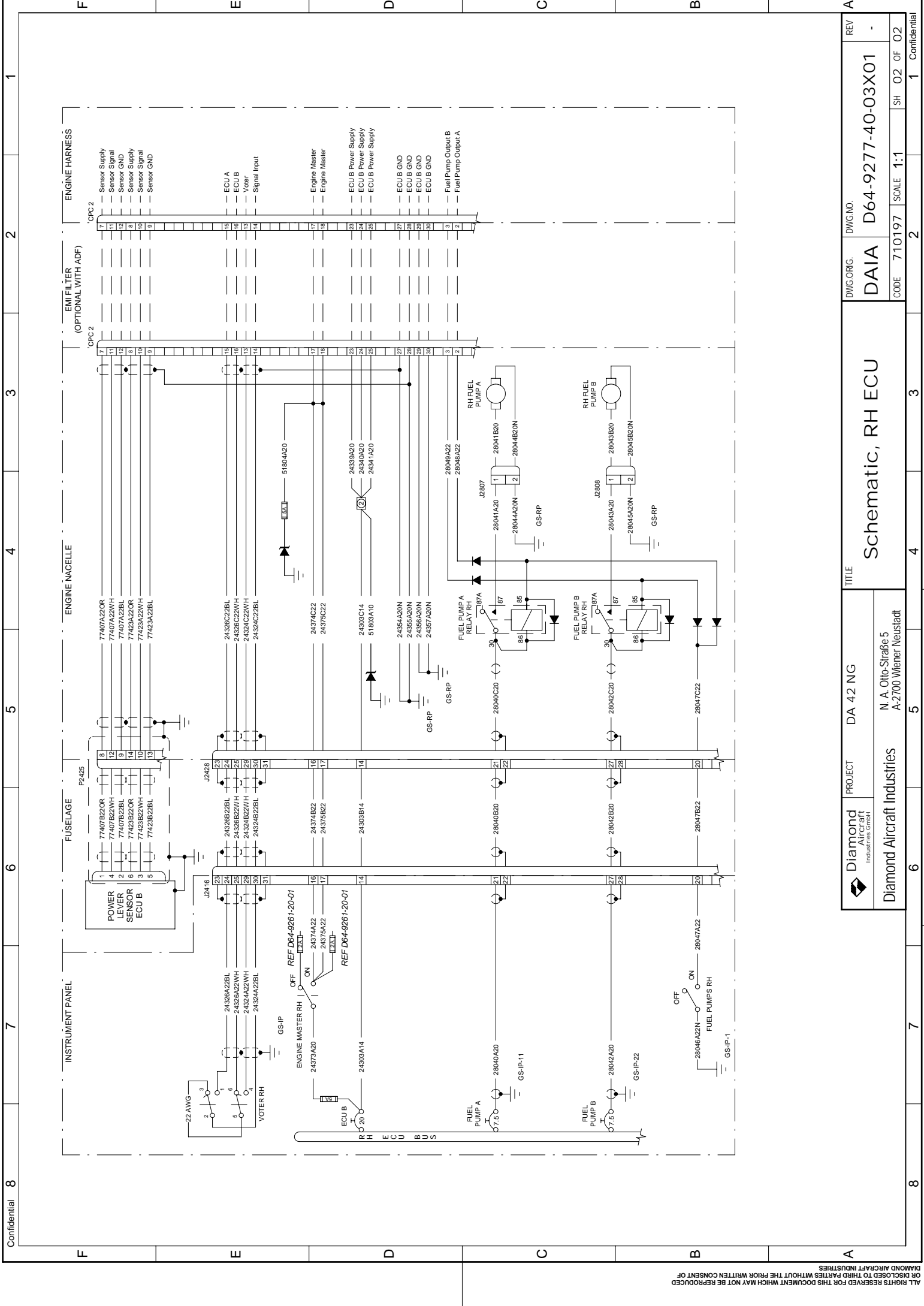

PROJECT		DA 42 NG		TITLE		Schematic, RH ECU		DWG. NO.		D64-9277-40-03X01		REV		-	
DIAMOND AIRCRAFT INDUSTRIES GmbH		N. A. Otto-Straße 5 A-2700 Wiener Neustadt		DAIA		710197		SCALE		1:1		SH		02 OF 02	
6		5		4		3		2		1		1		Confidential	